

LOADLIMITER 63M ULTRA B TYPE TP&N DISTRIBUTION BOARDS

Main Features

- Suitable only for Loadlimiter 63M MCBs and RCBOs with catalogue items beginning with M. **Not suitable for use with K prefix MCBs and RCBOs**
- Meets the requirements of EN 61439-3
- Neutral and earth terminal at 25mm² for each single-pole way
- Integral clean earth facility
- Switch disconnecter up to 125A can be mounted directly to the busbars, integral to the board.
- Alternative incomers can be accommodated using the kits below.

CATALOGUE NUMBERS

DISTRIBUTION BOARDS

Outgoing Triple Pole Ways	Product Code
4	DBX04M
6	DBX06M
8	DBX08M
12	DBX12M
16	DBX16M
20	DBX20M
24	DBX24M



KITS FOR ALTERNATIVE INCOMERS

(All incoming devices/neutral links are to be ordered separately)

Integral 125A incomer mounting/connection kit **DBXCKRM**
Kit contains everything required to fit 4 pole switch disconnectors or 4 pole RCCDs as incomers integral to board.

Integral incoming contactor mounting/connection kit **DBXCKCM**
Kit contains everything required to fit modular contactors as incomers integral to board.

Integral 250A incomer mounting/connection kit **DBXYB3M**
Kit contains everything required to fit any 3 Pole or 4 Pole YA3/YB3 Frame MCCB up to 250A integral to board and includes an add-on cable spreader enclosure



B TYPE DISTRIBUTION BOARD ACCESSORIES

125A integral metering kits

Contains MD1 meter, CT(s), fuses and all mountings and connections
125A single channel integral metering kit **DBXMK125M**
250A single channel integral metering kit **DBXMK250M**

Integral surge kits

Contains type 2 surge protection DSPM3PN, supply MCB and all mountings and connections
Integral surge kit **DBXSPM**

Both surge and meter kits can be fitted to the board at the same time.

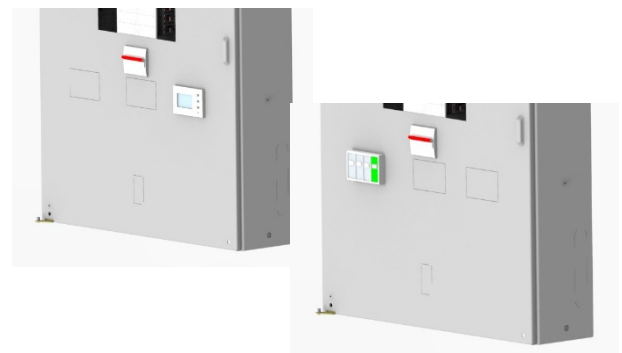

LOADLIMITER 63M ULTRA B TYPE TP&N DISTRIBUTION BOARDS

Busbar Terminal Blanks

Pack of 10 x busbar terminal blanks DAXTP

MCB Blanks

12 x MCB full module blanks for boards DBXBPM
4 x TP blanks and 12 x busbar DBXBP
terminal blanks DBXBM
5 x SP blanks and 5 x busbar DBXBH
terminal blanks

Conversion Kit

TP&N to SP&N Conversion Kit DBXTSM

Spares

End Plate DBXEPM
Fixing Kit up to 24 ways (includes grey DBX24FK
door catch, cable clamps, way labels
and ON/OFF label)

Joining Kits

DA18X to B Type Board Stacking Kit DBXSKAM

Terminal Bars

6 x useable single pole ways DBXT06
12 x useable single pole ways DBXT12
18 x useable single pole ways DBXT18
24 x useable single pole ways DBXT24

Direct connection kits

35mm² cables DBXD0
70mm² cables DBXDCK70M
150mm² cables DBXDCK150M

Earth Bar Kits

Earth Bar (12 x useable SP ways) DAXEB
Earth Bar isolation kit DBXL

Door Lock Kits

Cylinder door lock with keys DBXCL
Padlock bracket kit DBXPL

Double Earth Bar

Earth bar kit with a terminal for each DBXTE**X
outgoing way where ** = distribution
board number of ways

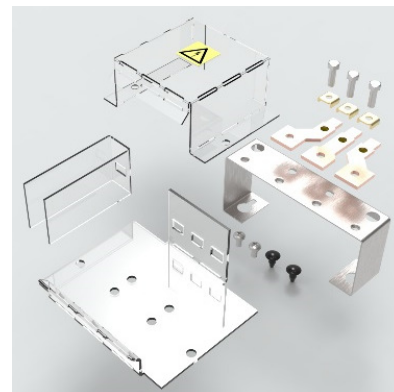
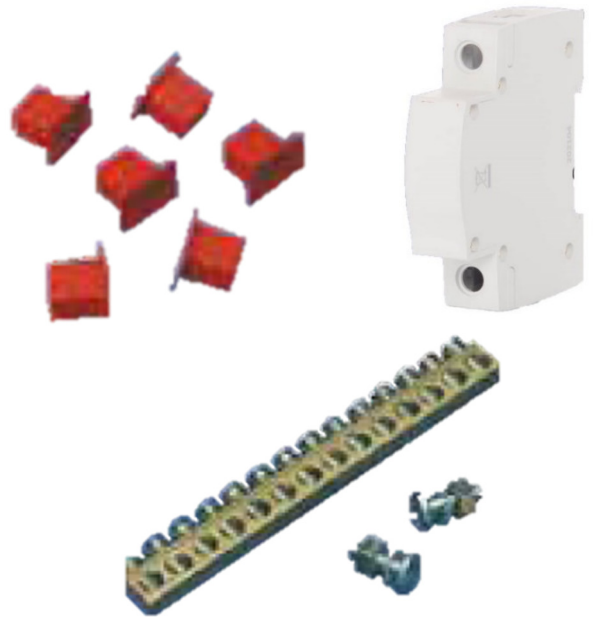

Technical data

Enclosure mounting	Surface
Busbar Current Rating	250A
Busbar short circuit rating	10kA for 250mS
External IP Rating	IP4X
Construction Outer	Painted 1.0mm (min) thick zinc plated sheet steel.
Construction Inner	1.2mm (min) thick aluminium-zinc coated sheet steel.
Busbar material	Copper bar to BS EN 13601, CW004A - R250
Busbar support material	Flame retardant, glass filled Nylon
Paint	Polyester powder coat, low smoke/fume, depth 40/120 microns colour RAL7035

LOADLIMITER 63M ULTRA B TYPE TP&N DISTRIBUTION BOARDS

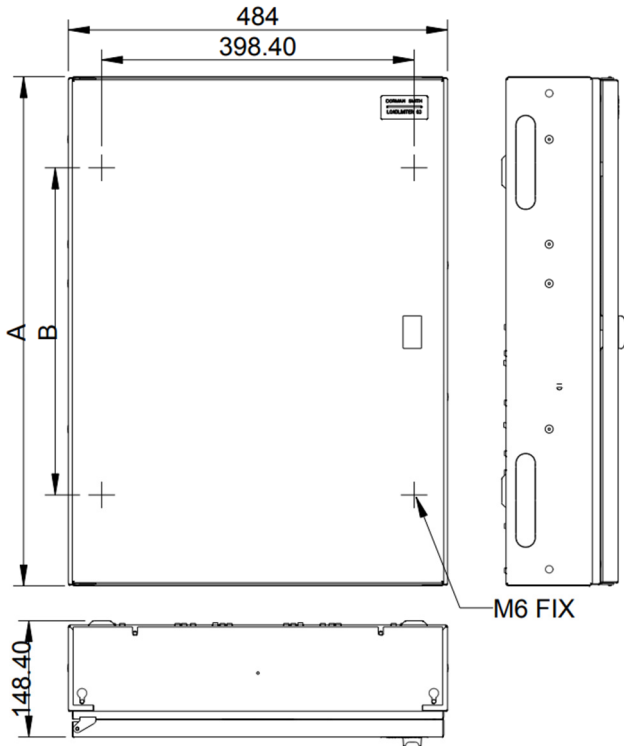

Cat. No.	Height A (mm)	Fixings B (mm)	Weight (kg)
DBX04M	544	310	10
DBX06M	598	364	11
DBX08M	651	418	12
DBX12M	758	526	15
DBX16M	865	634	18
DBX20M	1025	796	22
DBX24M	1132	904	27

