

SPM Series

Plug-in Surge Protection

The SPM series of modular surge protection devices provides protection of equipment connected to incoming low voltage AC power supplies against the damaging effects of transient over voltages caused by local lightning strikes, or the switching of electrical inductive or capacitive loads.

SPM devices are ideally suited for the protection of electrical distribution systems in buildings, generator set standby power supplies, combined heat and power, and co-generation applications against corrupted data and software, equipment failure and structural damage.

The SPM comprises separate 1, 2, 3 or 4 modular DIN rail connection bases, and a comprehensive range of 6kA or 40kA replaceable plug-in protection modules with integral mechanical status indication, which simply plug in.

Connection bases are available with or without, an additional remote indication facility for the communication of status information into building management or SCADA systems. For installation convenience the SPM series allows the selection and configuration of any number of modules to suit individual applications, or complete assemblies of the most popular configurations.

Description

The SPM series provides protection of expensive power assets against the damaging effects of mainsbourne transients through carefully matched high energy absorbing elements. Each type of plug-in protection module has a colour coded label to enable easy identification, eg: 6kA modules are purple, 40kA modules are blue, and neutral/earth modules are green. The highly flexible characteristics of the SPM allow the selection and configuration of any number of modules to suit the surge protection requirements of individual applications.

DIN Rail Modular Connection Bases

The SPM series offers DIN rail mount connection bases in 1, 2, 3 or 4 modules, into which the chosen surge protection module(s) simply plug-in. Connection bases can be supplied either with, or without, additional remote indication facility for communication of status information into building management or SCADA systems.

6kA SAD Plug-in Surge Protection Modules

Silicon avalanche diode (SAD) models conduct maximum current without any increase in clamping voltage. They offer extremely low clamping of <500 volts and an exceptionally fast response time of <5 nano seconds. The robust nature of this component technology offers long product life expectancy, ideally suited for high risk mobile telecom or other mission critical applications. 6kA modules are available in phase, and neutral to earth versions.

40kA MOV Plug-in Surge Protection Modules

Metal oxide varistor (MOV) models provide excellent clamping of transients within <10 nano seconds and are ideally suited for high/medium/low risk applications, as detailed in BS EN61643-11. 40kA modules are available in phase, and neutral to earth versions.

6kA and 40kA Neutral to Earth Plug-in Surge Protection Modules

SPM series offers neutral to earth protection for use in conjunction with 6kA SAD or 40kA MOV surge protection modules. Surge voltages affect system earth to neutral to a lesser degree than the main incoming AC supply, but should be protected against damaging transients.



Complete Assemblies

For installation convenience, the SPM series offers the most popular configurations of connection bases and surge protection modules as complete protection assemblies.

- 1, 2, 3 or 4 modular connection bases
- With or without remote indication facility
- 6kA or 40kA protection
- Single or three phase
- With or without neutral/earth protection

Features

- 1, 2, 3 or 4 modular DIN rail mount connection bases.
- 6kA SAD and 40kA MOV plug-in protection modules.
- Neutral to earth plug-in modules,
- Meets the requirements of BS EN62305-4:2006 (which replaced BS6651:1999 Annex C in August 2008) and BS EN61643-11/12 – SPD Type II, Class II (MOV models) and SPD Type III, Class III (SAD models)
- Tested to IEEE C62.41
- BS6651:1999 Annex C location category C (MOV models) and B (SAD models)
- Complete assemblies of the most popular configurations.
- Hot working replaceable plug-in modules.
- Thermal and current overload fusing.
- Protection status indication, Remote status indication option.

Benefits

- Protection of expensive power assets
- 6kA SAD models provide low clamping of <500V and <5 nano second response time
- Single and three phase options
- Remote monitoring into building management or SCADA systems
- Nuisance tripping avoidance of RCD's
- Simple installation
- Maintenance free
- Suitable for new or retrofit applications

Applications

- LV switchboards
- Sub distribution boards
- Generator sets
- Mobile telecommunications
- Windfarms
- PV Systems
- Railways

Approvals

- BS EN 61643-11

Quality Assurance

Approved to BS EN ISO9001

Operation

SPM surge protection devices offer 6kA or 40kA surge handling capabilities, which automatically reset after clamping lesser, more frequent surges. In the event of a surge exceeding the maximum capability of the chosen SPM device, the integral suppressor will fail, and the internal fusing will safely isolate the unit to protect the equipment connected to the supply. The mechanical status indicator, incorporated on the front face of every protection module, appears green when full protection is present. When the indicator shows red, there is no protection present, and the affected plug-in protection module must be replaced.

The DIN rail connection bases offer an additional remote indication option, where volt free terminals can be used to activate an alarm, or communicate the fault condition directly into a building management system. The switching contacts are completely isolated from the internal circuitry of the SPM device and may be used for AC mains voltage 230V RMS 1 Amp or 30V DC 2 Amp loads. Provided the live terminals of the connection base have been safely isolated, the plug-in modules can be installed or replaced without switching off the main supply.



Installation

SPM surge protection devices should be installed as close as possible to the incoming AC supply position. For example, in buildings, the SPM should be installed at the supply side of the main LV switchboard. Ideally, sub-distribution panels servicing specific areas, electronic equipment, or systems should also incorporate SPM surge protection modules. To provide isolation for maintenance and protection in high load circuits, it is recommended that SPM devices be installed on the load side of an MCB - Type C, or a fuse disconnecter 63A.

The modular connection bases are easily fitted onto a standard 35mm DIN rail for single or three phase system connection. The system rating or the peak current rating of the system to be protected will dictate the number and type of protection modules required, and therefore the number of connection bases used. The remote indication facility offered within connection bases is ideally suited for applications where inspection is restricted, allowing status information of SPM devices to be monitored through building management systems via volt free contacts.

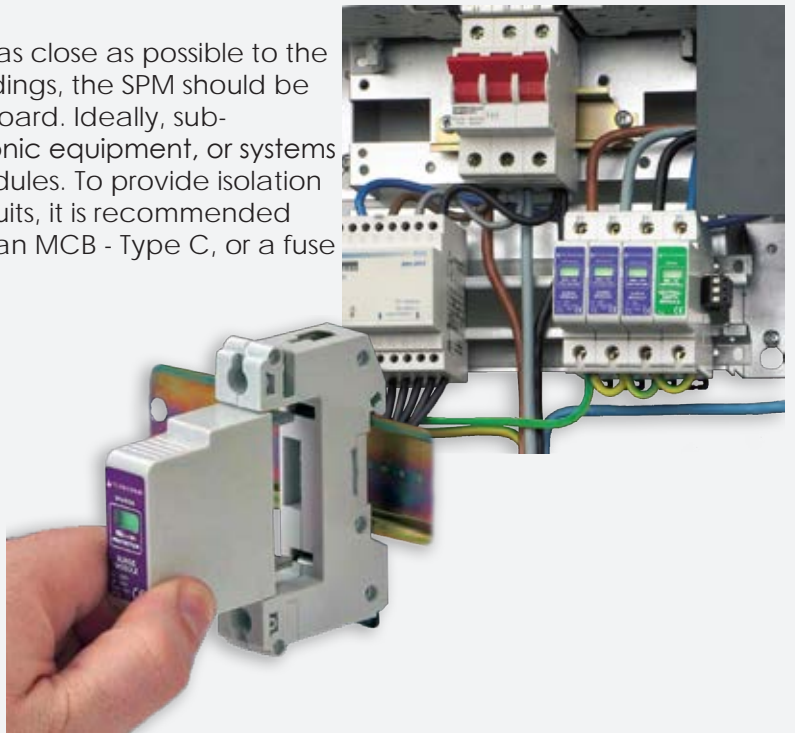

The replaceable surge protection modules simply plug-into the connection bases, and should be connected in parallel across the supply, either as multiples per phase or as a common neutral. Provided the live terminals of the connection base have been safely isolated, the plug-in modules can be installed or replaced without switching off the main supply. SPM surge protection devices are maintenance free, however, status indicators incorporated within the protection modules should be checked regularly to ensure full protection is present, particularly following local lightning activity

SPM Composition

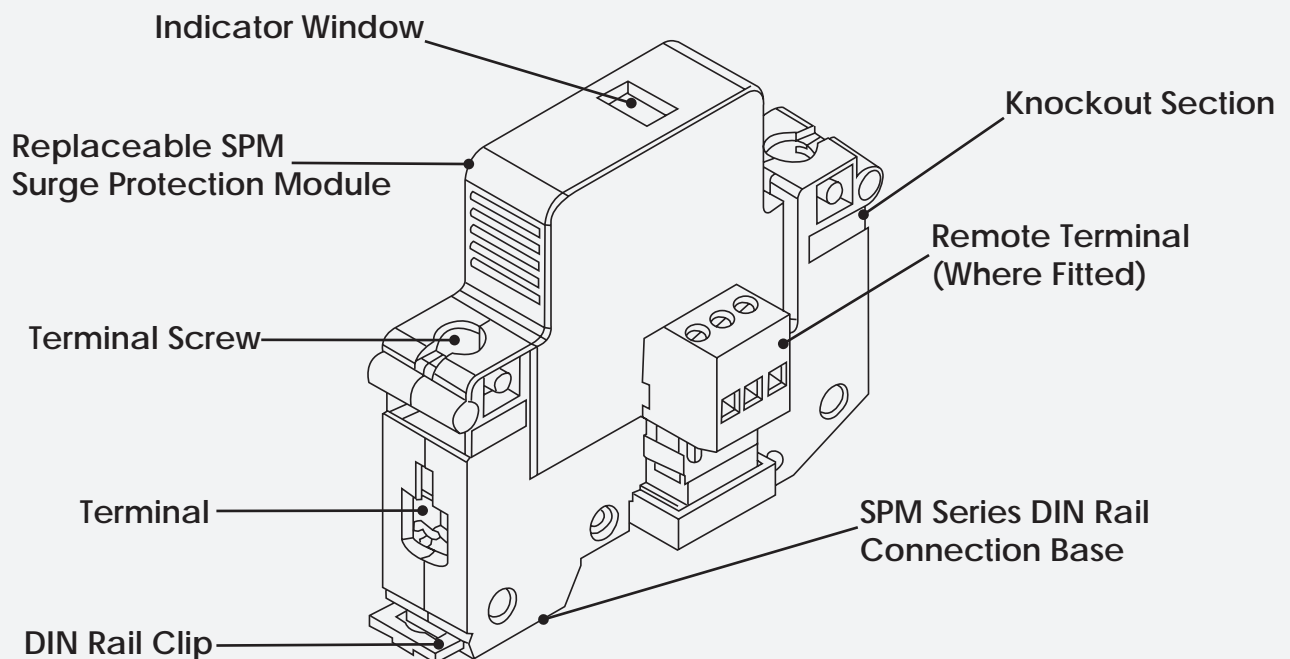

Specification	
Surge Handling Capabilities	6kA or 40kA
Surge Protection Technologies	6kA: SAD 40kA: MOV
Nominal Voltage Rating	Single phase: 230V RMS Three phase: 400V RMS
Operating Voltage Range	Single phase: 200-300 Volts Three phase: 380-515 Volts
Frequency	48/62 Hz
Maximum Current Rating	Not applicable (parallel connected)
Nominal Discharge Current (8/20 μ s) [In]	6kA SAD 20kA MOV
Max Surge Current Handling (8/20 μ s) [Imax]	6kA SAD 40kA MOV
Response Time	6kA SAD Models: <5ns 40kA MOV Models: <10ns
Short-circuit Withstand Capability	40kA with backup fuse 100A gL/gG max
Thermal Overload Fusing	120°C
Nominal Power Consumption	<10 μ A
Operating Temperature	-40 to +70°C
Protection at 5kA Up (8/20 μ s)	6kA SAD: <550V peak 40kA MOV: <1100V peak
Protection at Imax (8/20 μ s)	6kA SAD: <550V peak 40kA MOV: <1600V peak
Tested or Compliant With	BS EN 61643-11 BS EN 62305-4:2006 BS6651:1999 Annex C
Replaceable Plug-in Modules	2 pin connection to base
Protection Status Indicators	Mechanical flag mechanism Full protection present: Green No protection: Red
Remote Status Indication Option	Hard wired
Remote Indication Connections	Volt free N/O or N/C contacts
Terminals	Base: 16-35mm ² Remote: 2.5mm ² max
Remote Signalling Terminals	Rated at 230V RMS 1A or 30V DC 2A
Module and Base Material	Flame retardant ABS
Device Style	35mm DIN Rail mounted to EN 50022
Type According to BS EN 61643-11	SPD Type II, Class II (MOV models) and SPD Type III, Class III (SAD models)
Protection Rating	IP20
Dimensions (Single Module Assembly)	90mm high x 17.5mm wide x 75mm deep

Dimensions (mm)

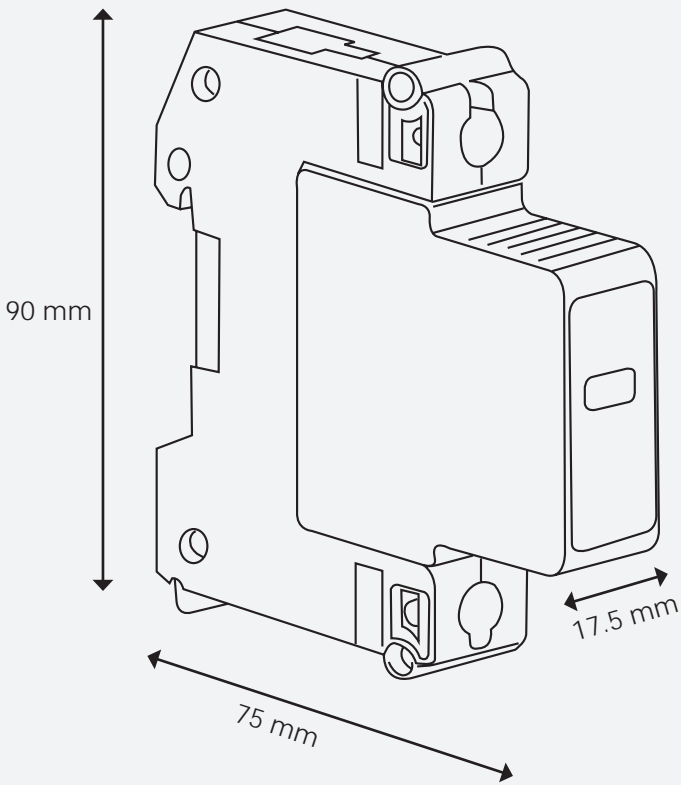

Assembly	High	Wide	Deep
1 Module	90	17.5	75
2 Module	90	35	75
3 Module	90	52.5	75
4 Module	90	70	75

Add 15mm to width if remote indication facility required



Wiring Connections

SPM connection bases should be connected in parallel across the supply to be protected. The connecting cable does not carry the supply current, only the current associated with suppressing the transient overvoltage. SPM surge protection devices should be installed on the load side of an MCB or fuse disconnector, enabling isolation for maintenance if required, and protection of high load circuits. Each module is internally fused for both thermal and over current protection and will discriminate with the supply MCB or fuse disconnector. If RCD's are used, the SPM must be fitted in front of the device to avoid nuisance tripping.

Single Phase Wiring

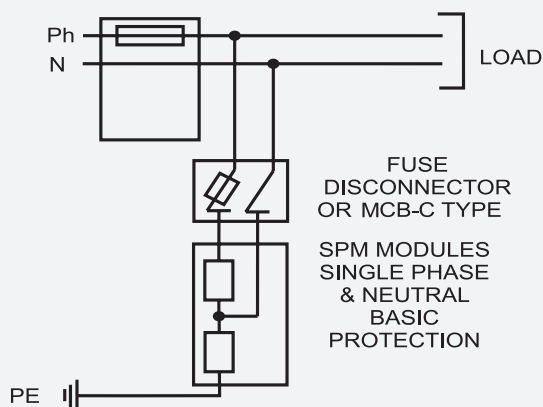

Three Phase Wiring

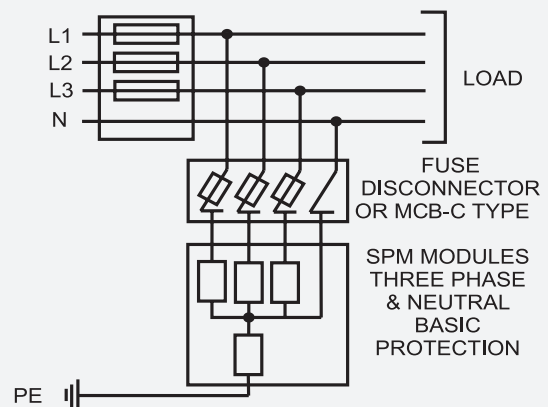

TNS wiring: the neutral conductor and the earth conductor are separated.

Single Phase TNS Wiring

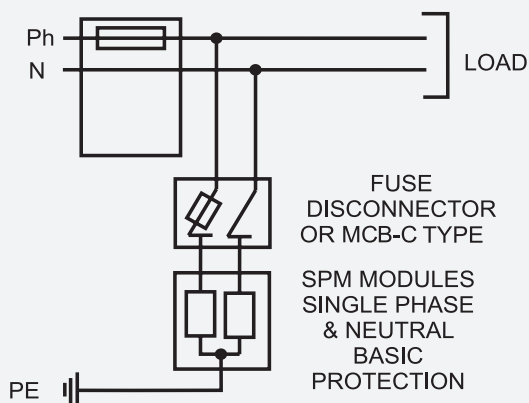

Three Phase TNS Wiring

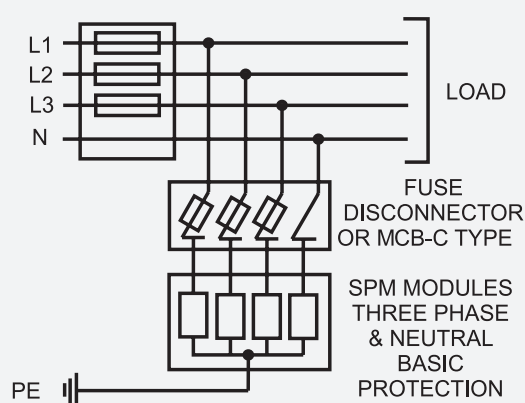

TNC wiring: the neutral conductor and the protective conductor merge into one (PEN) conductor

Single Phase TNC Wiring

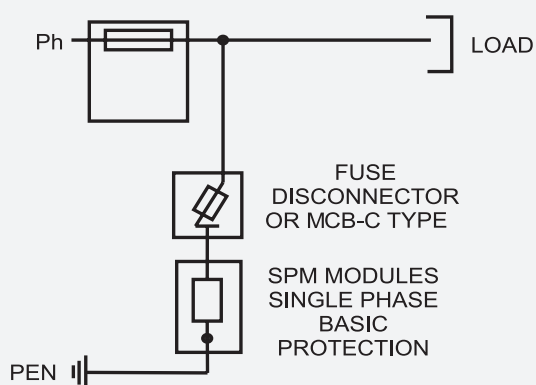

Three Phase TNC Wiring

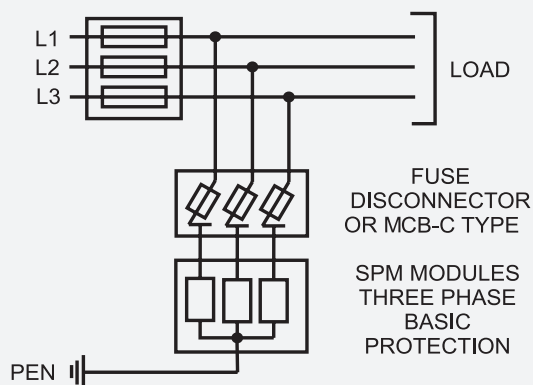



Fusing

SPM surge protection devices are suitable for direct connection to a system with line protection rated up to 100A using 16mm² min connecting cables, or above 100A providing in-line over current protection is fitted. In the event of a surge exceeding the maximum surge capability of the chosen SPM device, additional in-line disconnecting fuses will prevent rupture of the main fuse and disconnection of the supply. In order to discriminate with the supply fuse, the in-line fuse should be in the ratio of 1:2. The in-line fuses can be replaced by MCB's Type C.

Product Codes		
6kA SAD Plug-In Surge Protection Modules & Base Assemblies		Catalogue No
6kA Single Phase (L-N, L-E)		A1SPM/6/230
6kA Single Phase with Remote Indication (L-N, L-E)		A1SPM/6/230R
6kA Single Phase with Neutral/Earth		A1SPM/6/230N
6kA Single Phase with Neutral/Earth & Remote Indication		A1SPM/6/230NR
6kA Three Phase (L-N, L-E)		A3SPM/6/230
6kA Three Phase with Remote Indication (L-N, L-E)		A3SPM/6/230R
6kA Three phase with Neutral/Earth		A3SPM/6/230N
6kA Three Phase with Neutral/Earth & Remote Indication		A3SPM/6/230NR
6kA Neutral/Earth		A1SPM/NE/6/230

Product Codes		
40kA MOV Plug-In Surge Protection Modules & Base Assemblies		Catalogue No
40kA Single Phase (L-N, L-E)		A1SPM/40/230
40kA Single Phase with Remote Indication (L-N, L-E)		A1SPM/40/230R
40kA Single Phase with Neutral/Earth		A1SPM/40/230N
40kA Single Phase with Neutral/Earth & Remote Indication		A1SPM/40/230NR
40kA Three Phase (L-N, L-E)		A3SPM/40/230
40kA Three phase with Remote Indication (L-N, L-E)		A3SPM/40/230R
40kA Three Phase with Neutral/Earth		A3SPM/40/230N
40kA Three Phase with Neutral/Earth & Remote Indication		A3SPM/40/230NR
40kA Neutral/Earth		A1SPM/NE/40/230

Product Codes		
Replacement Plug-In Surge Protection Modules		Catalogue No
6kA SAD Module		SPM/6/230
6kA SAD Neutral/Earth Module		SPM/NE/6/230
40kA MOV Module		SPM/40/230
40kA MOV Neutral/Earth Module		SPM/NE/40/230

Product Codes		
DIN Rail Modular Connection Bases		Catalogue No
Single Module Base		SPMB1
Single Module Base With Remote Indication		SPMB1/R
Two Module Base		SPMB2
Two Module Base With Remote Indication		SPMB2/R
Three Module Base		SPMB3
Three Module Base With Remote Indication		SPMB3/R
Four Module Base		SPMB4
Four Module Base With Remote Indication		SPMB4/R

All of the above information, including drawings, illustrations and graphic designs, reflects our present understanding and is to the best of our knowledge and belief correct and reliable.

Users, however, should independently evaluate the suitability of each product for the desired application. Under no circumstances does this constitute an assurance of any particular quality or performance. Such an assurance is only provided in the context of our product specifications or explicit contractual arrangements. Our liability for these products is set forth in our standard terms and conditions of sale..