

## LOADBANK 250 FORM 3 TYPE 2 MCCB PANEL BOARD 800A

### Main Features

- Meets the requirements of EN 61439-2
- ASTA certified busbars rated at 50kA for 1 second
- Form 3b type 2 as standard
- Can accommodate both thermal magnetic and electronic YA3S devices
- Supplied with top plate and two side plates as standard
- Ingress protection of IP3X or IP4X with optional door kit fitted
- Outgoing YA3/YB3 MCCBs and accessories are to be ordered separately.



### CATALOGUE NUMBERS

#### PANEL BOARDS

Outgoing Triple Pole Ways	Modular Height	Panel Board Product Code	Door Kit Product Code
6	4	LB806YA3EBM	LBDD06
12	6	LB812YA3EBM	LBDD12
18	8	LB818YA3EBM	LBDD18

#### PANEL BOARD ACCESSORIES

Description	Product Code
3 pole blanking plate	LBBP3PYA3
Spare End Plate	LGES
Cylinder Door Lock	DBXCL
Padlocking Door Kit	DBXPL
Connections to horizontal busbars in Modis 12 Ultra	MCLB800

### Technical data

Enclosure mounting	Surface
Busbar Current Rating	800A
Busbar short circuit rating (Icw)	50kA for 1 second
Rated voltage (Un)	415Vac
Rated operational Voltage (Ue)	415Vac
Rated insulation Voltage (Ui)	500Vac
Rated impulse withstand voltage	(Uimp): 6kV
External IP Rating	IP3X as standard, IP4X with optional doors fitted
Internal form of segregation	Form 3b type 2, IP2X
Construction Outer	Painted 1.2/1.6mm (min) thick zinc plated sheet steel.
Construction Inner	Painted 1.2mm (min) thick zinc plated sheet steel and 1.2mm thick aluminium-zinc coated sheet steel.
Internal segregation materials	Aluminium-zinc coated sheet steel and rigid polycarbonate barriers
Busbar /connection material	High conductivity copper
Busbar support material	Flame retardant, glass filled Nylon
Paint	Polyester powder coat, low smoke/fume, depth 40/120 microns colour RAL7035

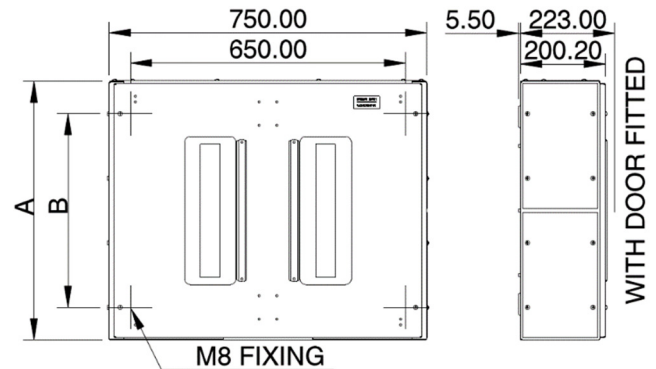

Cat. No.	Height A (mm)	Fixings B (mm)	Weight (kg)
LB806YA3EBM	609	457	42
LB812YA3EBM	914	762	62
LB818YA3EBM	1219	1066	78