

LOADBANK 125 YB1 MCCB PANEL BOARD 250A

Main Features

- Meets the requirements of EN 61439-2
- ASTA certified busbars rated at 25kA for 1 second
- Form 3b type 2 as standard
- Ingress protection of IP3X
- Incoming meter and surge can be fitted within the enclosure
- Removable end plates top and bottom
- All necessary connections to connect incoming device are supplied
- Incoming YB3 and outgoing YB1 MCCBs and accessories are to be ordered separately as required.

CATALOGUE NUMBERS

PANEL BOARDS

Outgoing Triple Pole Ways	Panel Board Product Code
4	PB204YB1
6	PB206YB1
8	PB208YB1
12	PB212YB1

PANEL BOARD ACCESSORIES

Description	Product Code
Cable spreader box	PBCSB
Service centre 32 modules	PBSC32
Direct connection kit 250A	PBDC2
Type 1 surge kit	PBSPT1
Type 2 surge kit	PBSPT2
Incoming meter kit 250A	PB250MK
Initial outgoing meter kit (complete with fuses and tap off supply connections)*	PB125MK
Additional outgoing meter kit (complete with meter-to-meter supply connection)*	PB125MKA
Incoming MCCB neutral link	YB3NLPB
Front plate blanks (per TP outgoing way)	LBYB1BP3P

*Outgoing meters mount in PBSC32 max 8 meters per unit

Technical data

Enclosure mounting	Surface
Busbar Current Rating	250A
Busbar short circuit rating (Icw)	25kA for 1 second
Rated operational Voltage (Ue)	415Vac
Rated insulation Voltage (Ui)	690Vac
Rated impulse withstand voltage (Uimp)	6kV
External IP Rating	IP3X
Internal form of segregation	Form 3b type 2, IP2X
Construction Outer	Painted 1.2 (min) thick zinc plated sheet steel.
Construction Inner	1.2mm (min) thick aluminium-zinc coated sheet steel.
Internal segregation materials	Aluminium-zinc coated sheet steel and rigid polycarbonate barriers
Busbar /connection material	High conductivity copper
Busbar support material	Flame retardant, glass filled Nylon
Paint	Polyester powder coat, low smoke/fume, depth 40/120 microns colour RAL7035

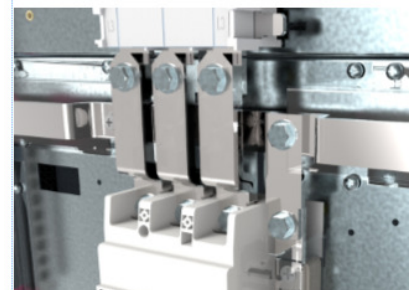

LOADBANK 125 YB1 MCCB PANEL BOARD 250A

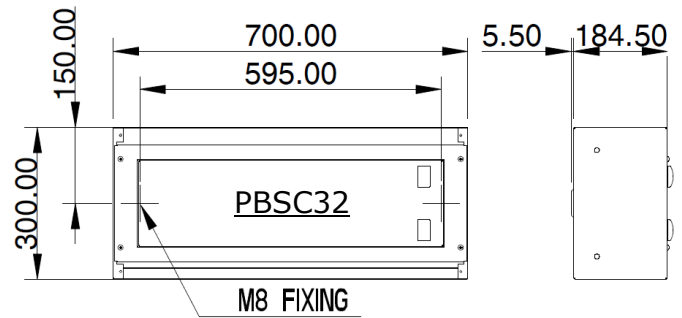
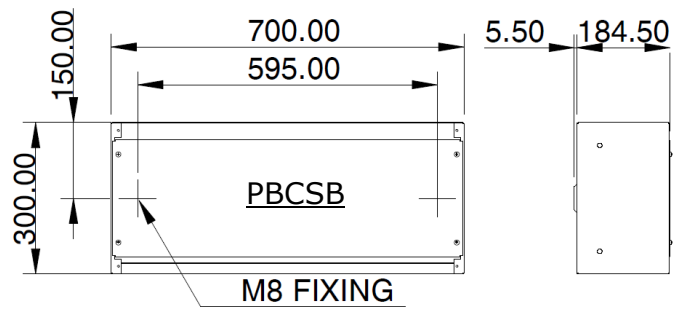
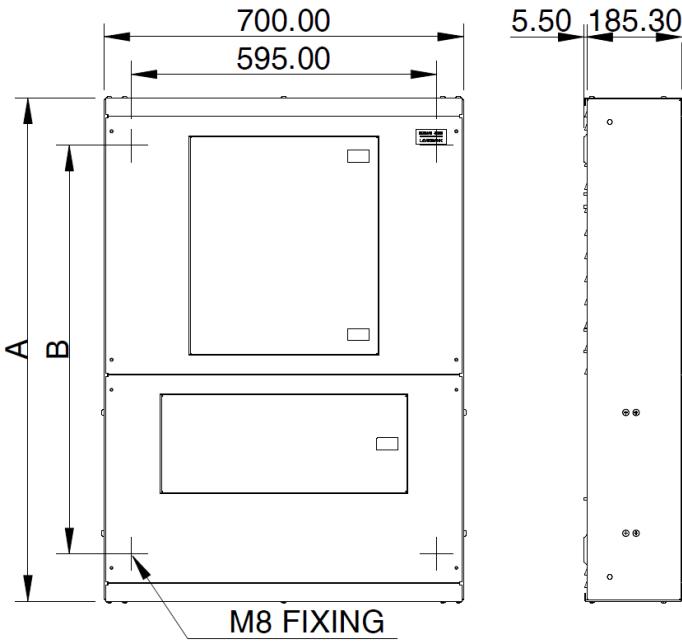

Cat. No.	Height A (mm)	Fixings B (mm)	Weight (kg)
PB204YB1	835	645	31
PB206YB1	910	720	34
PB208YB1	985	795	37
PB212YB1	1135	945	44