

HOUSING FOR 1 X YA7 MCCB
FITTING INSTRUCTIONS

SHEET 1 OF 2

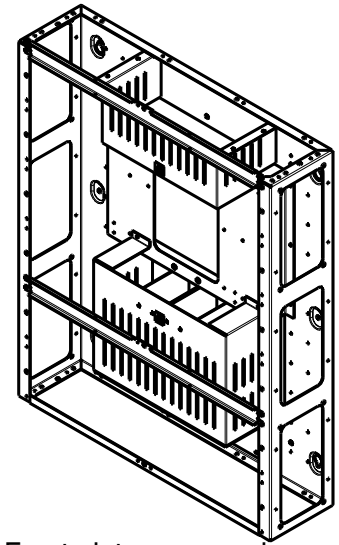
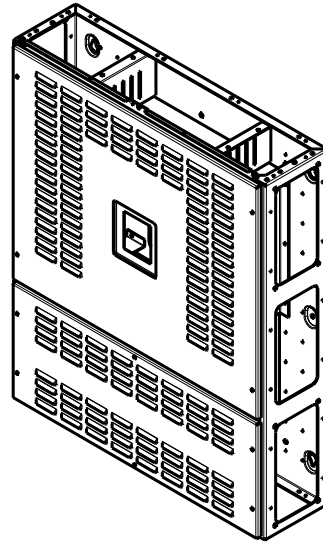
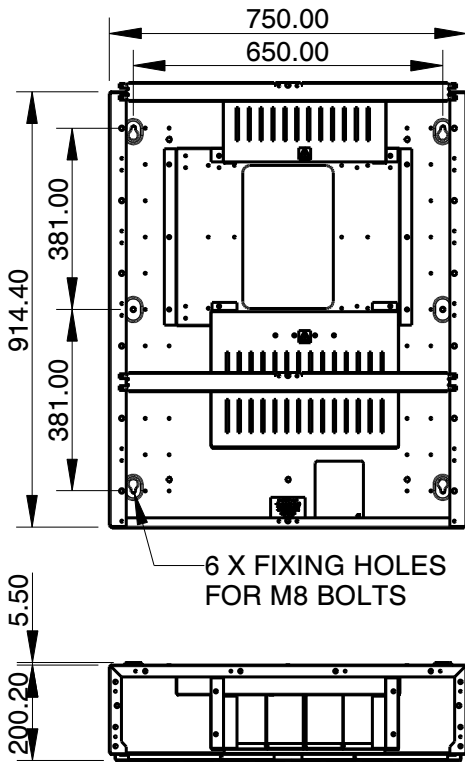

Front plates removed
for clarity

NOTE:- Unit is shown as supplied.
MCCB, neutral link and busbar connections
are supplied separately under catalogue
numbers shown on sheet 2.

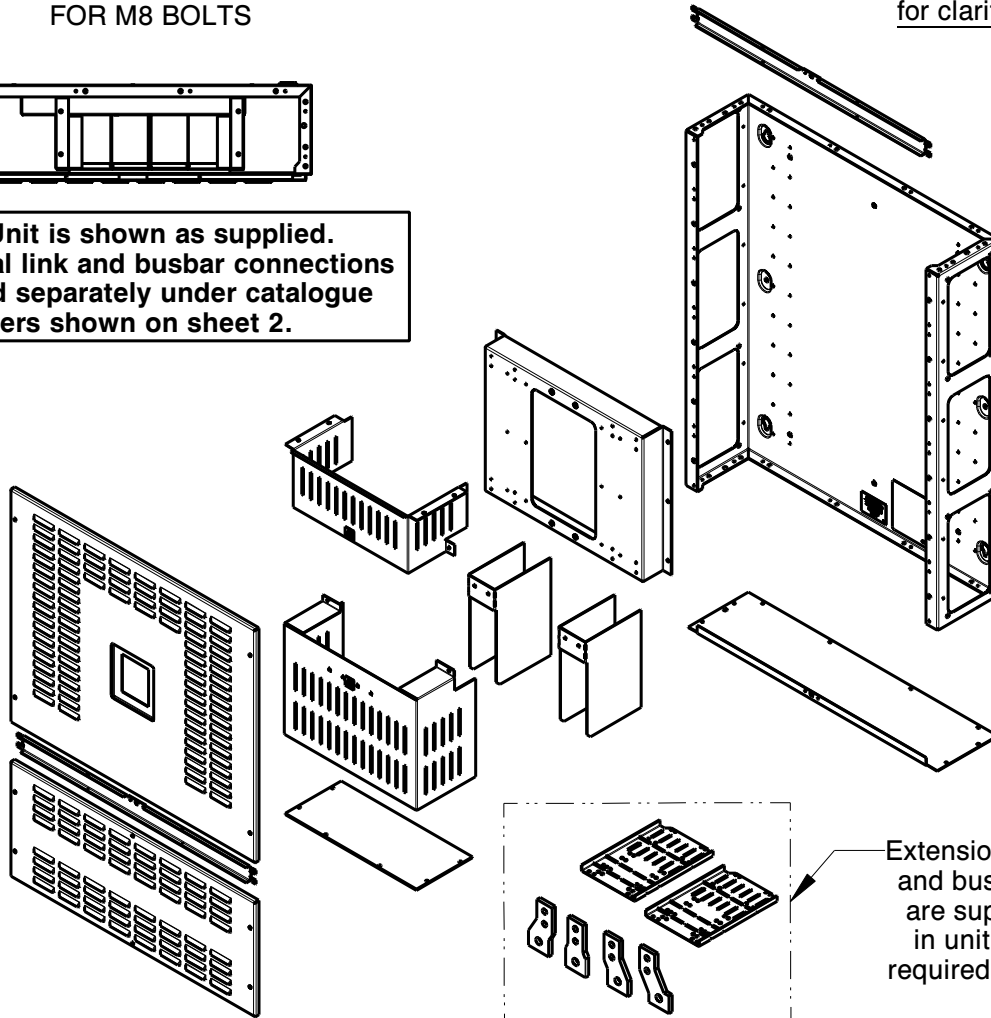

TESTING AND COMMISSIONING

Before the unit and the installation of which it forms a part are commissioned they must be tested, in accordance with the requirements of the latest edition of the Requirements for Electrical Installations.

Installation and operation must be in accordance with published data, instructions and diagrams and any relevant national and local regulations

HOUSING FOR 1 X YA7 MCCB
FITTING INSTRUCTIONS

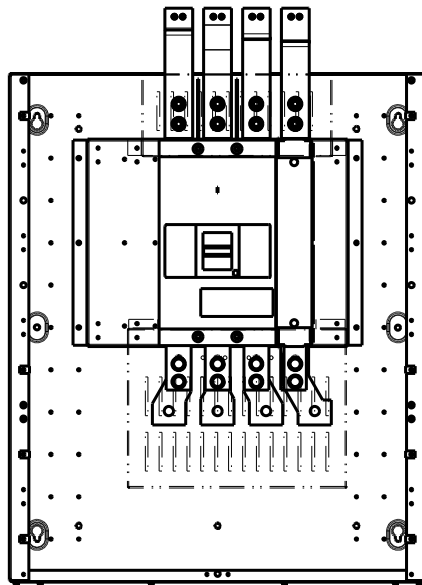
SHEET 2 OF 2



Front plates removed and
shrouds dimmed for clarity

BUSBAR
CONNECTIONS
- MCYA7

YA7 FRAME MCCB
(TRIPLE POLE OR 4 POLE)
- REFER TO CATALOGUE
FOR NUMBERS

NEUTRAL LINK
- YA7NL

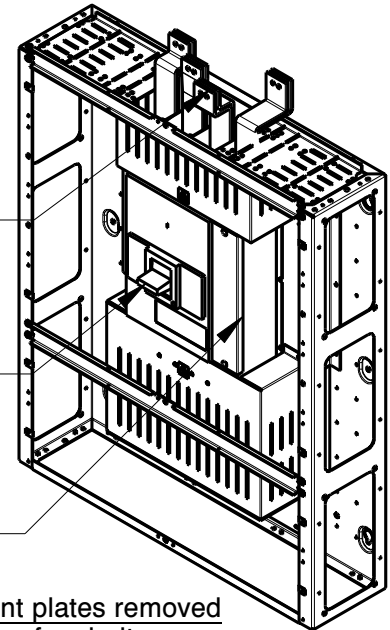

Front plates removed
for clarity

FITTING MCCB AND CONNECTIONS

NOTE: If used as an outgoing unit, this enclosure should **NOT** be mounted below the horizontal busbar. When mounted above the horizontal busbars, for top cable access, turn the unit upside down so that the MCCB mounting plate is closest to the busbars. Front plates can be refitted in their original orientation ie with louvres opening downwards.

- 1) Remove all front/end plates and fix the unit to the wall using suitable bolts (not supplied).
- 2) Bolt the unit to the horizontal busbar housing using the M6 x 16 bolts and washers supplied in the cross strap fastener kit.
- 3) Remove top and bottom shrouds and mount the YA7 frame MCCB to the mounting plate using the screws supplied with the MCCB. Refer to instructions supplied with MCCB for torque figures, setting details and additional information concerning the MCCB.
- 4) If required mount the neutral link to the right of the MCCB with the self tapping screws supplied with the neutral link kit.
- 5) Fit the extension terminal kit supplied to the incoming terminals of the MCCB. Instructions are supplied with the kit.
- 6) Fit the connections between the MCCB and busbars. Instructions are supplied with the kit.
- 7) Install incoming cables using appropriate cable glands and sockets. To avoid swarf and other foreign objects entering the enclosure always remove gland plates to cut cable / trunking entries.
- 8) Check the tightness of all connections and refit top and bottom shrouds ensuring interphase barriers fixed to the bottom shroud are in between the phases of the incoming supply.
- 9) Fit the horizontal busbar barriers between the unit and the busbars by bolting the barrier to the busbar box flange and the connection shroud using the M5 x 12 bolts, nuts and washers supplied in the horizontal busbar barrier fix kit. **NOTE:** Cut barrier along slots as required and fit with the barrier flange protruding into the busbar area.
- 10) Use the earth kit required to attach earth connection to either end of unit as required.
- 11) Refit cross straps and front plates. **NOTE:** Before fitting the front cover check the tightness of connections and ensure that all shrouds are correctly located and secured in place.

RECOMMENDED TORQUE FIGURES (unless otherwise stated)

SIZE	M5	M6	M8	M10	M12	M16
TORQUE Nm	5.5	9.5	17	28	45	91