

**HOUSING FOR 1 X YA5 MCCB**
**FITTING INSTRUCTIONS**

SHEET 1 OF 2

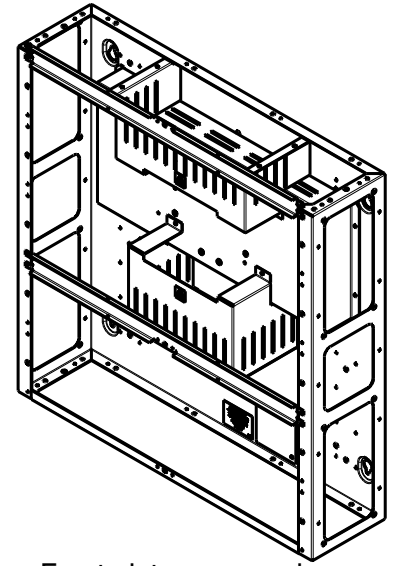
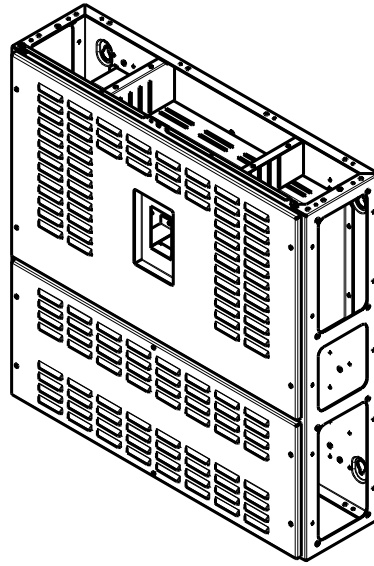
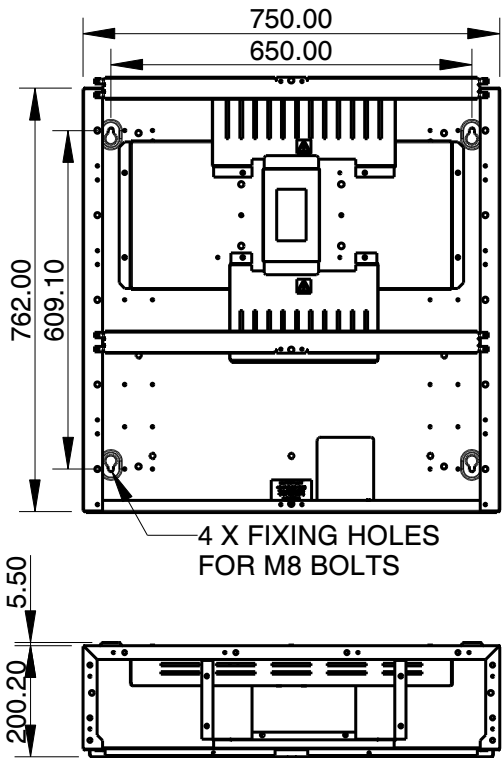

Front plates removed  
for clarity

**NOTE:-** Unit is shown as supplied. MCCB, neutral link and busbar connections are supplied separately under catalogue numbers shown on sheet 2.

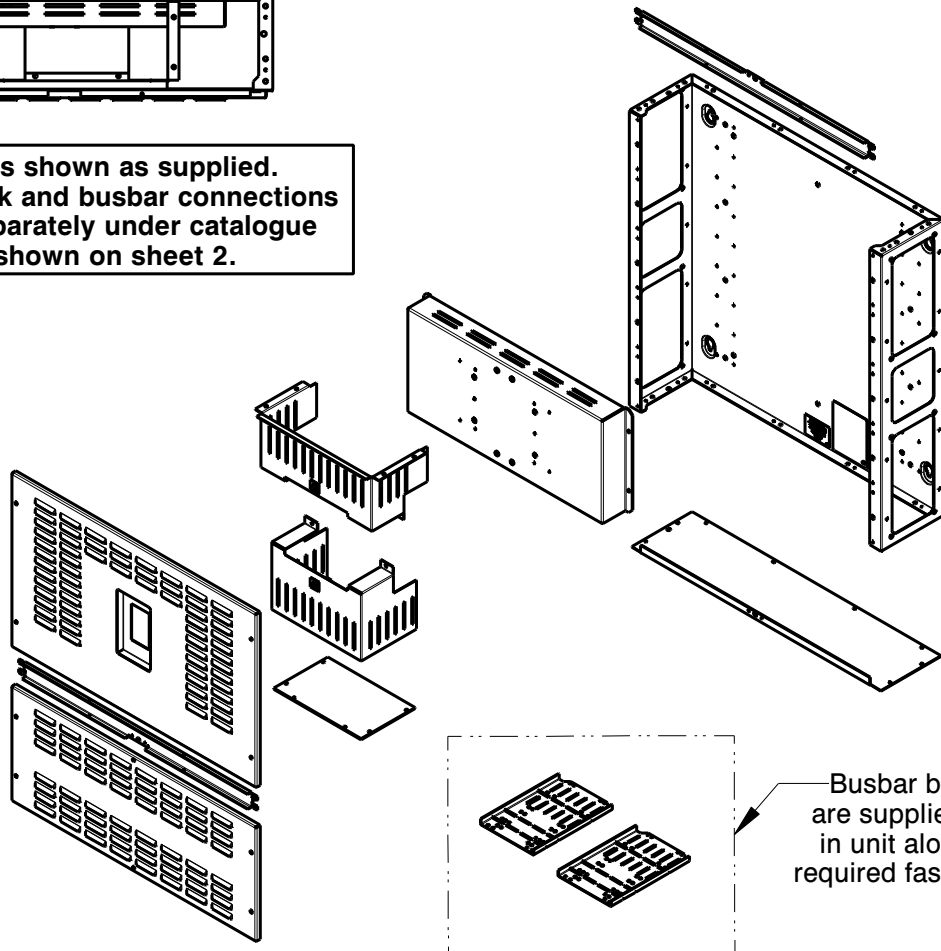

Busbar barriers are supplied loose in unit along with required fastener kits

**TESTING AND COMMISSIONING**

Before the unit and the installation of which it forms a part are commissioned they must be tested, in accordance with the requirements of the latest edition of the Requirements for Electrical Installations.

Installation and operation must be in accordance with published data, instructions and diagrams and any relevant national and local regulations

**HOUSING FOR 1 X YA5 MCCB**
**FITTING INSTRUCTIONS**

SHEET 2 OF 2

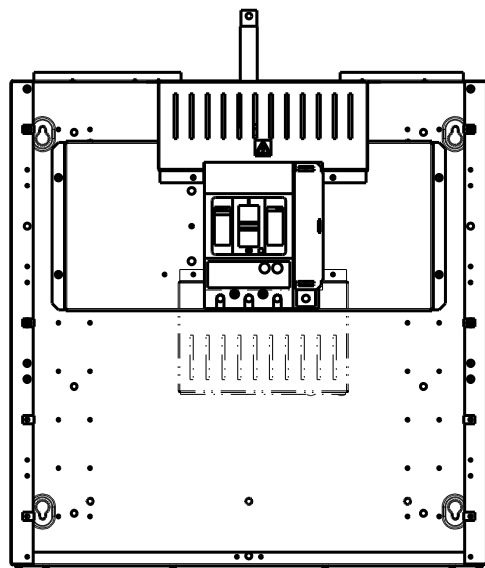

Front plates removed and shrouds dimmed for clarity

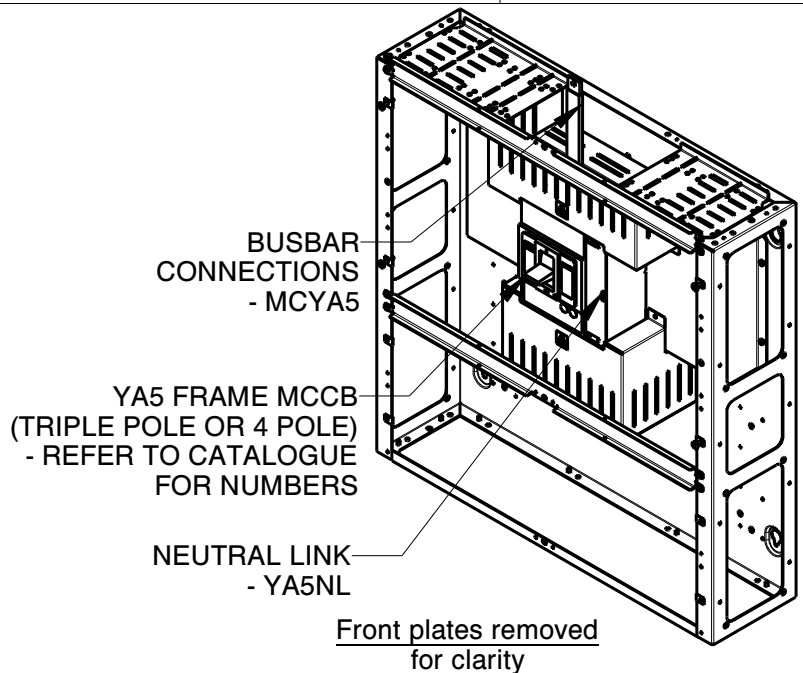

Front plates removed for clarity

**FITTING MCCB AND CONNECTIONS**

**NOTE:** When mounted above the horizontal busbars, for top cable access, turn the unit upside down so that the MCCB mounting plate is closest to the busbars. Front plates can be refitted in their original orientation ie with louvres opening downwards.

- 1) Remove all front/end plates and fix the unit to the wall using suitable bolts (not supplied).
- 2) Bolt the unit to the horizontal busbar housing using the M6 x 16 bolts and washers supplied in the cross strap fastener kit.
- 3) Remove top and bottom shrouds and mount the YA5 frame MCCB to the mounting plate using the screws supplied with the MCCB. Refer to instructions supplied with MCCB for torque figures, setting details and additional information concerning the MCCB.
- 4) If required mount the neutral link to the right of the MCCB with the self tapping screws supplied with the neutral link kit.
- 5) Fit the connections between the MCCB and busbars. Instructions are supplied with the kit.
- 6) Install incoming cables using appropriate cable glands and sockets. To avoid swarf and other foreign objects entering the enclosure always remove gland plates to cut cable / trunking entries.
- 7) Check the tightness of all connections and refit top and bottom shrouds.
- 8) Fit the horizontal busbar barriers between the unit and the busbars by bolting the barrier to the busbar box flange and the connection shroud using the M5 x 12 bolts, nuts and washers supplied in the horizontal busbar barrier fix kit. **NOTE:** Cut barrier along slots as required and fit with the barrier flange protruding into the busbar area.
- 9) Use the earth kit required to attach earth connection to either end of unit as required.
- 10) Refit cross straps and front plates. **NOTE:** Before fitting the front cover check the tightness of connections and ensure that all shrouds are correctly located and secured in place.

**RECOMMENDED TORQUE FIGURES (unless otherwise stated)**

SIZE	M5	M6	M8	M10	M12	M16
TORQUE Nm	5.5	9.5	17	28	45	91