

## YA7 MCCB INCOMER HOUSING

### FITTING INSTRUCTIONS

SHEET 1 OF 2

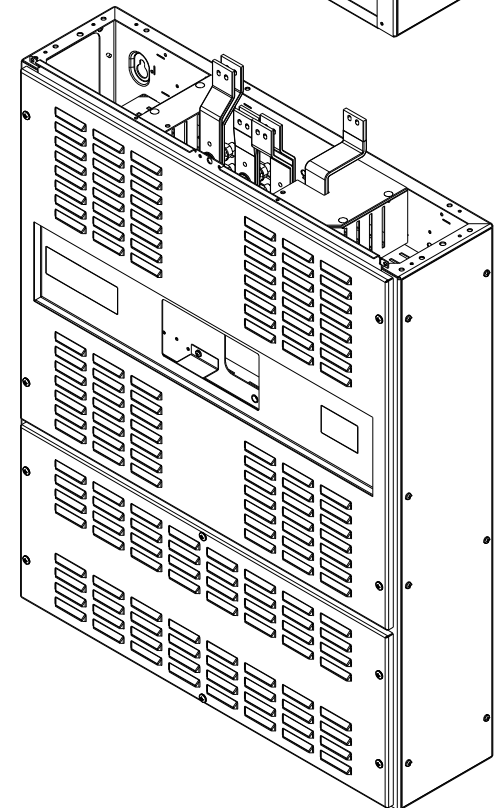
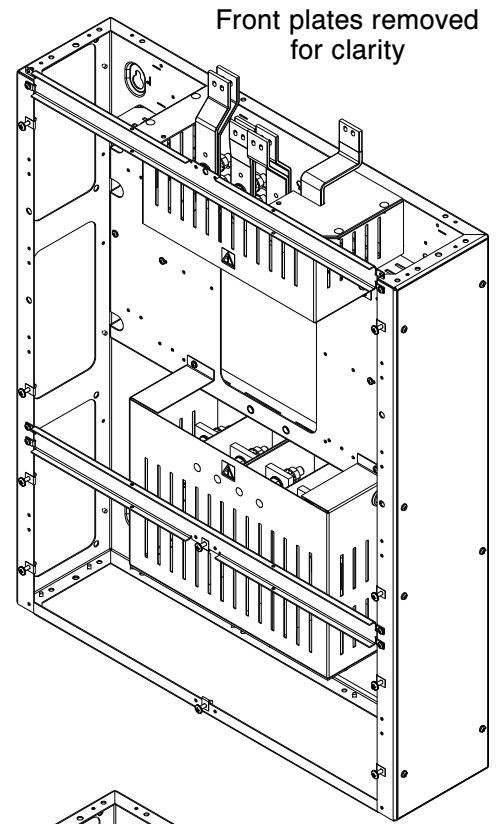
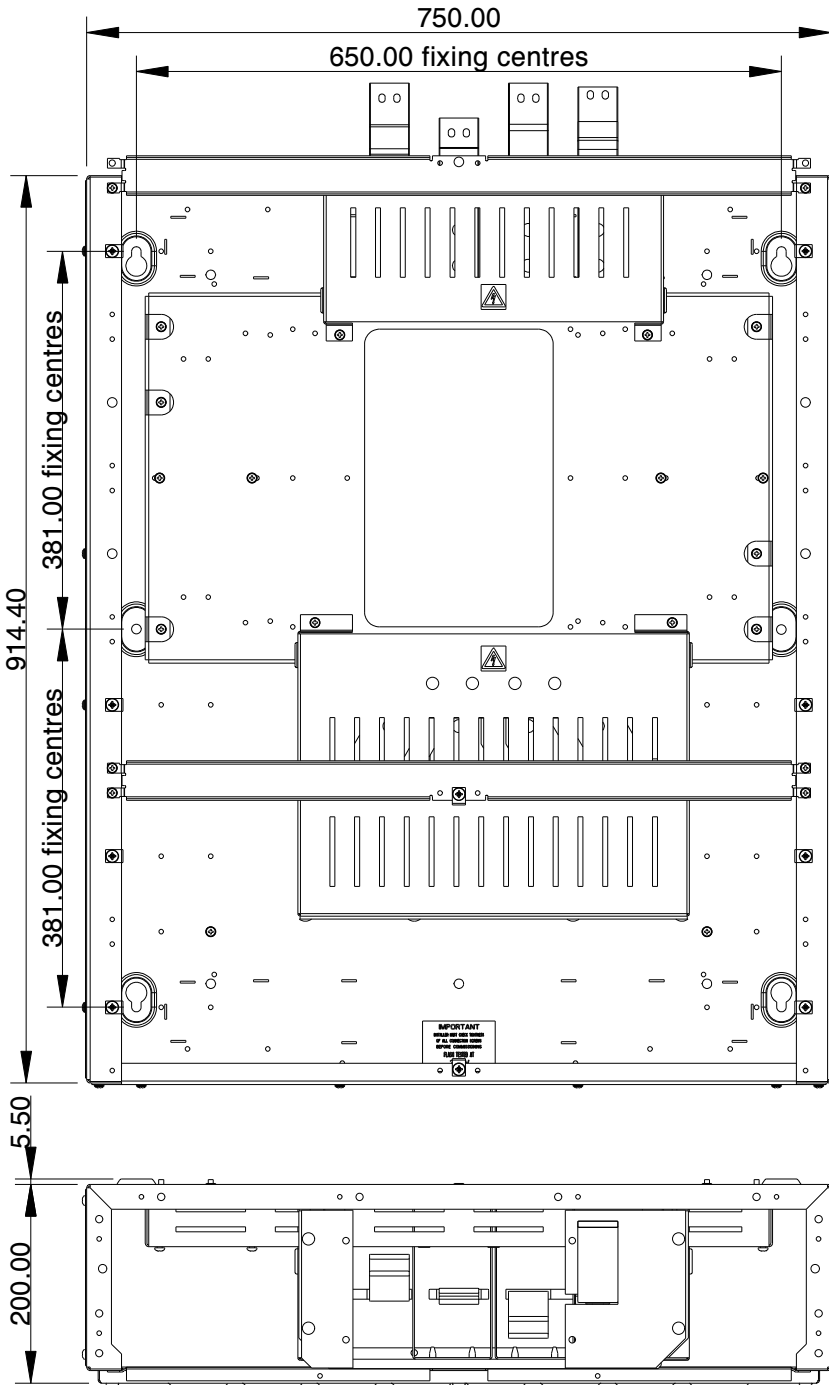

NOTE:- Unit is shown as supplied c/w side plates, busbar connections, extension terminals, connection shrouds & all necessary fasteners.

MCCB and neutral link to be ordered separately.

#### TESTING AND COMMISSIONING

Before the unit and the installation of which it forms a part are commissioned they must be tested, in accordance with the requirements of the latest edition of the Requirements for Electrical Installations.

Installation and operation must be in accordance with published data, instructions and diagrams and any relevant national and local regulations

## YA7 MCCB INCOMER HOUSING

### FITTING INSTRUCTIONS

SHEET 2 OF 2

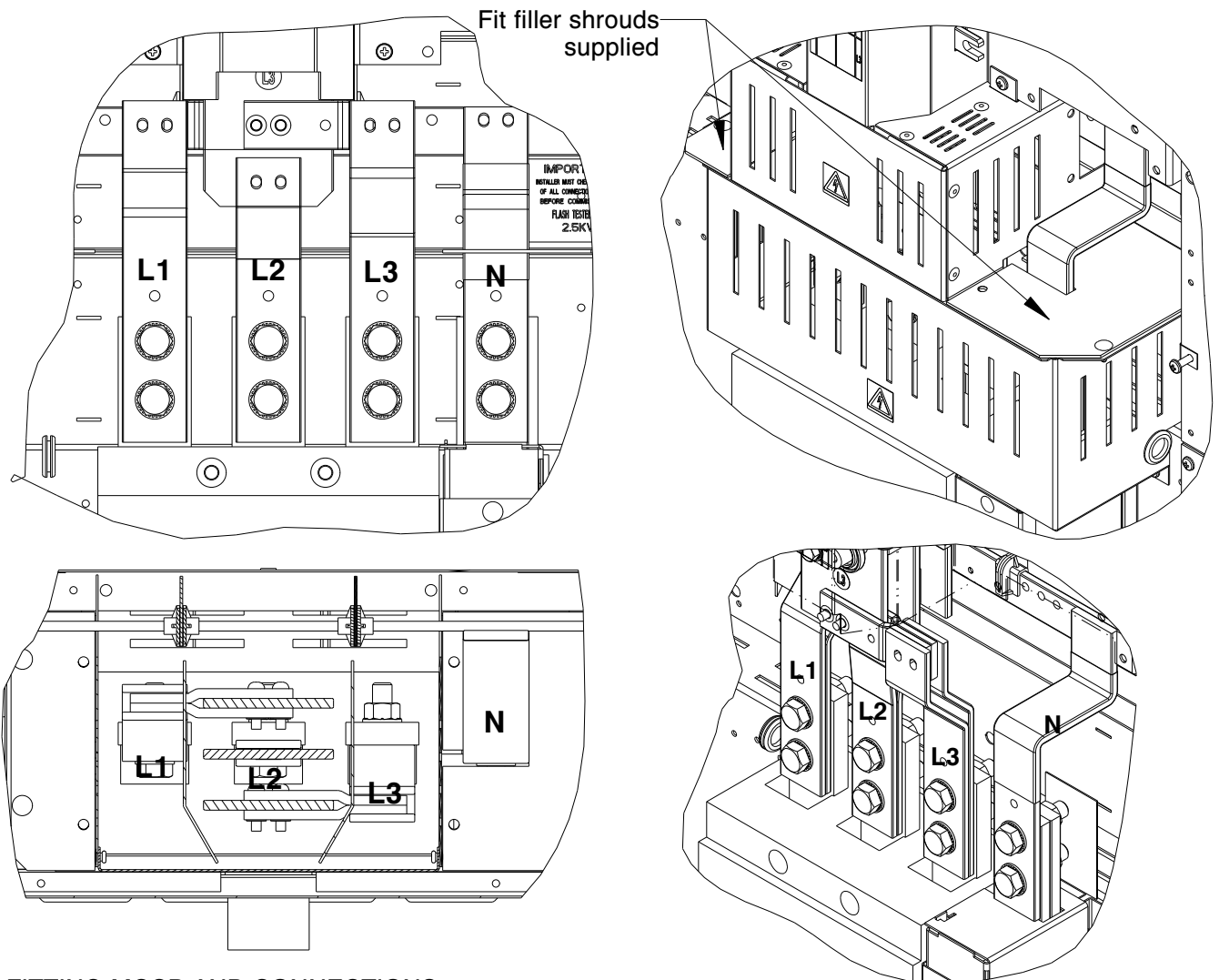

#### FITTING MCCB AND CONNECTIONS

NOTE: When mounted above a panelboard, for top cable access, turn the unit upside down so that the MCCB mounting plate is closest to the busbars. Front plates can be refitted in their original orientation ie with louvres opening downwards.

- 1) Remove all front/end plates and fix the unit to the wall using suitable bolts (not supplied).
- 2) Bolt the unit to the panelboard housing using the M6 x 16 bolts and washers supplied in the cross strap fastener kit.
- 3) Remove top and bottom shrouds and mount the YA7 frame MCCB to the mounting plate using the screws supplied with the MCCB. Refer to instructions supplied with MCCB for torque figures, setting details and additional information concerning the MCCB.
- 4) If required mount the neutral link to the right of the MCCB with the self tapping screws supplied with the neutral link kit.
- 5) Fit the connections between the MCCB and busbars as shown above. Note if 4 pole MCCB is fitted the supplied packer must be fitted between connections and MCCB neutral terminal.
- 6) Fit the interphase barriers supplied with the MCCB to the top of the MCCB.
- 7) Fit the extension terminal kit supplied to the incoming terminals of the MCCB.
- 8) Install incoming cables using appropriate cable glands and sockets. To avoid swarf and other foreign objects entering the enclosure always remove gland plates to cut cable / trunking entries.
- 9) Check the tightness of all connections and refit all shrouds ensuring interphase barriers fixed to the bottom shroud are in between the phases of the incoming supply.
- 10) Fit the filler shrouds to the incomer top shroud and panel board shroud as shown above.
- 11) Use the earth kit required to attach earth connection to either end of unit as required.
- 12) Refit cross straps and front plates. NOTE: Before fitting the front cover check the tightness of connections and ensure that all shrouds are correctly located and secured in place.

#### RECOMMENDED TORQUE FIGURES (unless otherwise stated)

SIZE	M5	M6	M8	M10	M12	M16
TORQUE Nm	5.5	9.5	17	28	45	91