

## YA6 CONNECTIONS TO HORIZONTAL BUSBAR

### FITTING INSTRUCTIONS

SHEET 1 OF 1

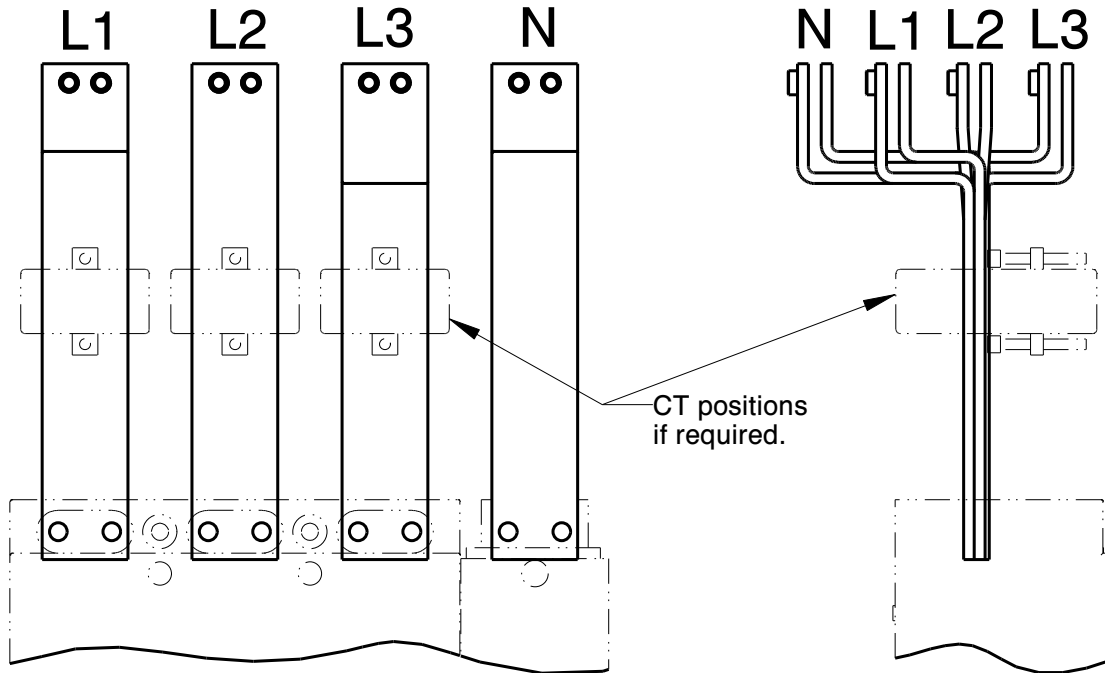

#### Copper sizes

2 laminations of 40 x 5 for phases & neutral.

#### **Notes:**

Connections work with triple pole or 4 pole MCCBs and either above or below the horizontal busbars.

The rear connection at the busbar end are inserted for M6 bolts for ease of assembly.

All required fasteners are supplied with the connections kit.

Use the supplied phase label markers to mark the connections after fitting.

**Interphase barriers must always be fitted to the top of the MCCB. Barriers are either supplied loose with the MCCB or as part of the shroud when incoming top.**

**Before refitting shrouds and front covers check the tightness of all connections.**

Installation and operation must be in accordance with published data, instructions and diagrams and any relevant national and local regulations

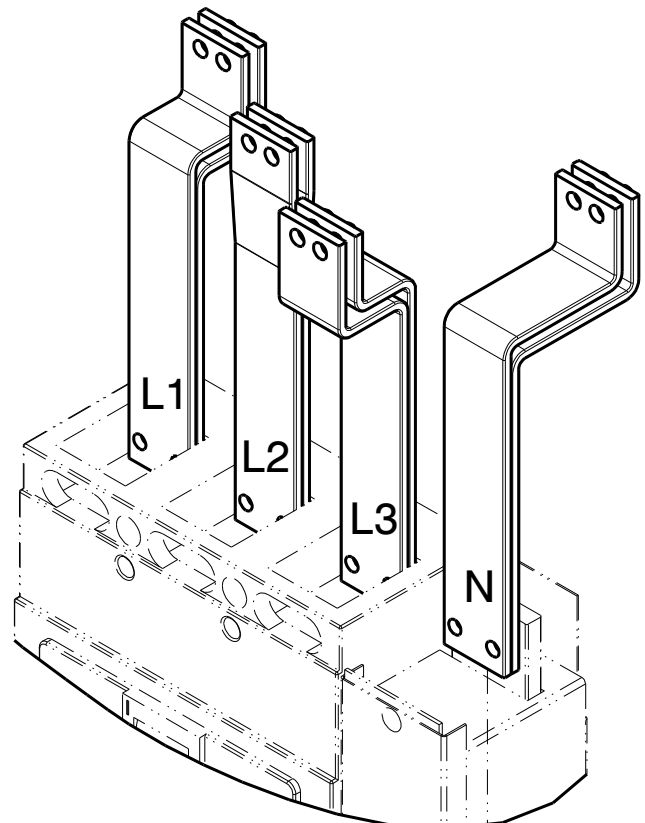

#### RECOMMENDED TORQUE FIGURES (unless otherwise stated)

SIZE	M5	M6	M8	M10	M12	M16
TORQUE Nm	5.5	9.5	17	28	45	91