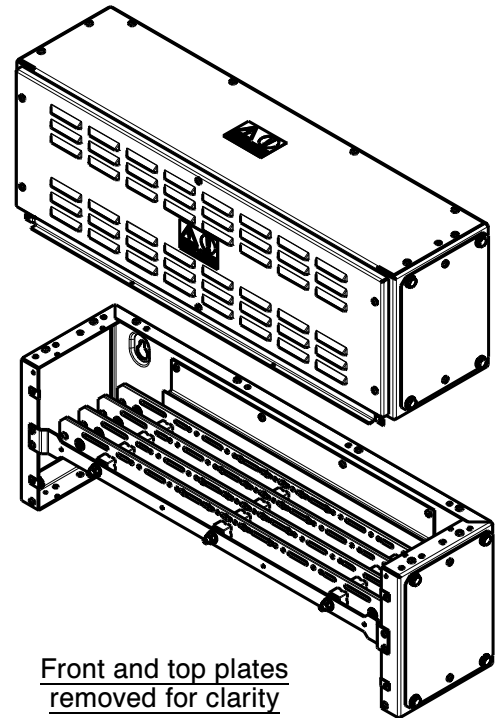
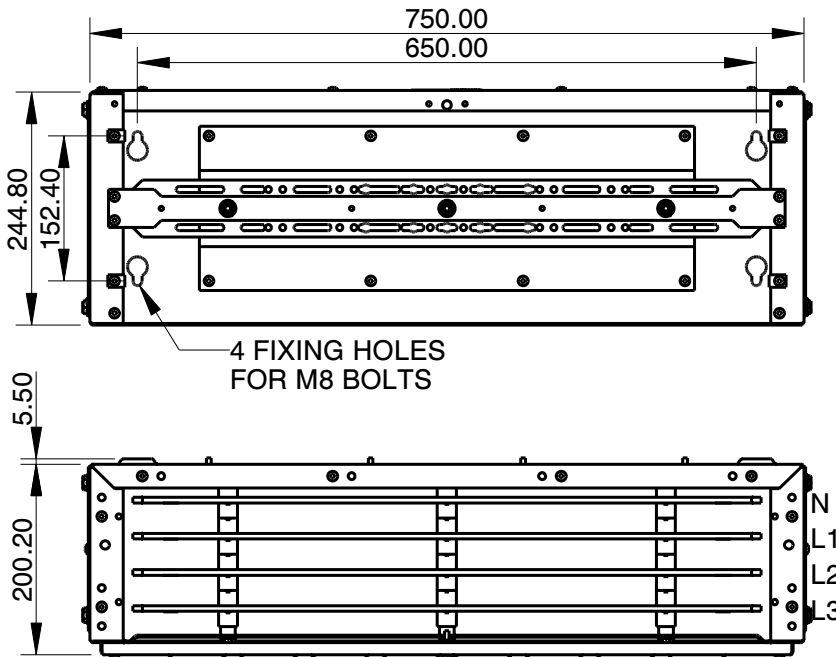

**BUSBAR CHAMBER 630A**
**FITTING INSTRUCTIONS**

SHEET 1 OF 1

**MOUNTING INSTRUCTIONS**

- 1) Remove all front/end plates and fix the unit to the wall using suitable bolts (not supplied).
- 2) If required end plate can be refitted on inside of chamber and secured using 2 self tapping screws to blank busbar off and still allow additional enclosures/cableways to be fitted to the side of the enclosure.
- 3) Use the earth kit required to attach earth connection to either end of unit as required.
- 4) Refit cross straps and front plates.

**TESTING AND COMMISSIONING**

Before the unit and the installation of which it forms a part are commissioned they must be tested, in accordance with the requirements of the latest edition of the Requirements for Electrical Installations.

Installation and operation must be in accordance with published data, instructions and diagrams and any relevant national and local regulations

**RECOMMENDED TORQUE FIGURES (unless otherwise stated)**

SIZE	M5	M6	M8	M10	M12	M16
TORQUE Nm	5.5	9.5	17	28	45	91