

Instruction Manual for Moulded Case Circuit Breakers

**Dorman Smith Switchgear Limited**  
 8 Swinbourne Drive  
 Springwood Industrial Estate  
 Braintree Essex  
 CM7 2YG UK  
 Tel: +44 (0) 844 225 1063  
 Fax: +44 (0) 844 225 1064

2G0420SAA( KRB-5289)

## 1 Safety Notices

Be sure to read these instructions and other documents accompanying this product. Please familiarise yourself with handling of this product, safety information, and all other precautions before mounting, using, servicing or inspection. In these instructions, safety notices are divided into "Warning" and "Caution" according to the hazard level:

**Warning** : A warning notice with this symbol indicates that neglecting the suggested procedure or practice could result in lethal or serious personal injury.

**Caution** : A caution notice with this symbol indicates that neglecting the suggested procedure or practice could result in moderate or slight personal injury and/or property damage.

Note that failing to observe **Caution** notices could result in serious results in some cases. Because safety notices contain important information, be sure to read and observe them.

### Mounting Precautions

(For detailed mounting dimensions, refer to the TemBreak2 catalogue.)

#### Caution

- Electrical work should only be undertaken by suitably qualified persons.
- Do not place the product in an area that is subject to high temperature, high humidity, excessive dusty air, corrosive gas, strong vibration and shock, or other unusual conditions. Mounting in such areas could cause a fire or malfunction.
- Be careful to prevent foreign objects (debris, concrete powder, iron powder, etc.) and rainwater from entering product. These materials inside the product could cause a fire or malfunction.
- Prior to commencing any work on the product, open an upstream circuit breaker or isolator to ensure that no voltage is applied to the product. Otherwise, electrical shock may result.
- When connecting cable or busbar to the product, tighten terminal screws to the torque specified in this manual. Otherwise, a fire could result.
- For front-connected breakers, Insulate all bare conductors of the line side until the breaker end. Insulate all bare conductors by insulating tape or the like. Insufficient insulation may result in short-circuit.
- Do not block the arc gas vents of the product to ensure adequate arc space. Blocking these vents could result in failure of circuit interruption.

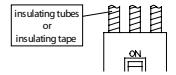

### Handling Precautions

#### Warning

- Never touch terminals. Otherwise, electric shock may result.

#### Caution

- When the breaker trips open automatically, remove the cause, then return the handle to the I (ON) position. Should a fault be interrupted, the breaker must be inspected. Otherwise, a fire may result.

### Maintenance Precautions

#### Caution

- Service and/or inspection of the product must be done by persons having expert knowledge.
- Before servicing or inspecting the product, open an upstream circuit breaker or the like to isolate all sources of power. Otherwise, electric shock may result.
- Regularly check that the MCCB terminal screws are tightened to torque values shown within this manual, failure to do so may result in fire.

### Other Precautions

- Do not carry this product by accessory leads, as this may cause damage to the product.
- Unauthorised opening of the breaker cover will invalidate product warranty.
- When installing the product, use wires or conductors, the cross sectional areas of which accommodate the rated current of the product. Using wires or conductors with inadequate cross sectional areas may cause false tripping and overheat.

## 2 Packaged Items/Assembly tools

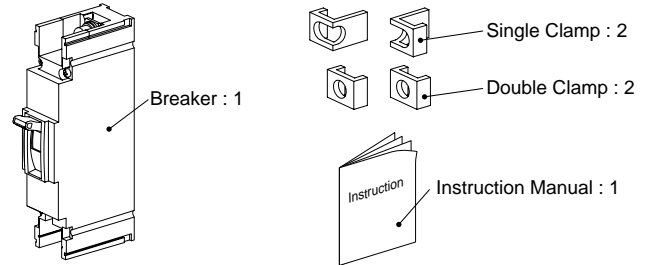

Connections/Poles		Type	
		Qty	YA2, YA3
Front Connected (FC)	1P	2	(M8X16)
	1P	2	(M4X65)

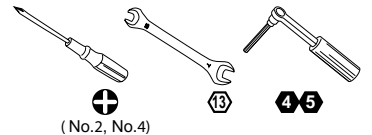

## 3 Operating Instructions

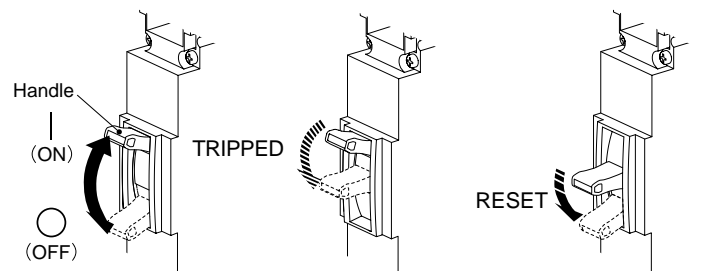

		Type	Operation effort			
I (ON) ⇒ O (OFF)	YA2		11N	TRIP ⇒ O (OFF) (RESET)	YA2	44N
O (OFF) ⇒ I (ON)			19N			
I (ON) ⇒ O (OFF)	YA3		28N		YA3	68N
O (OFF) ⇒ I (ON)			22N			

## Breaker Mounting Procedure

Single or Isolate mounting

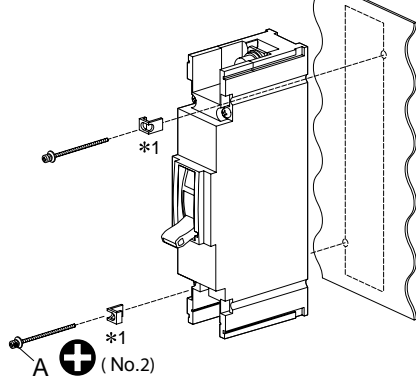

Side by side multiple mounting

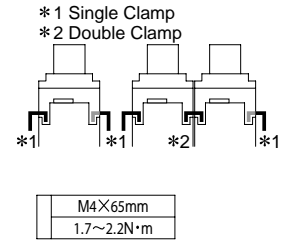
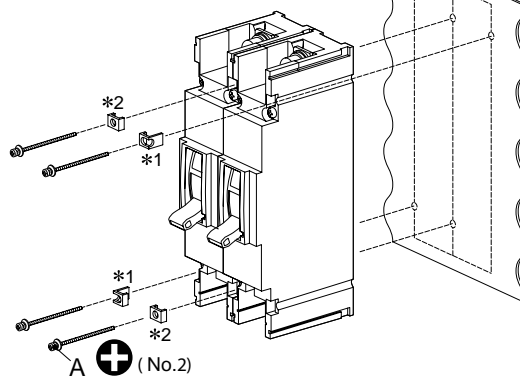

## 5 Conductor Connection Procedure

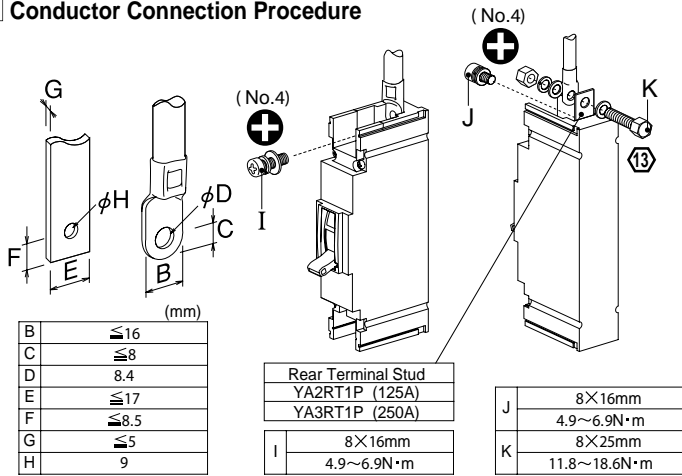

## 6 Procedure for mounting Pillar Terminal Cable Clamps, Solderless Terminals

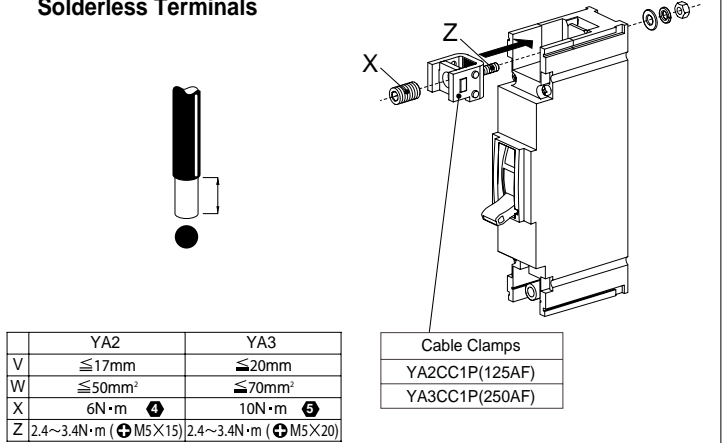

## 7 Fitting Shunt Trip

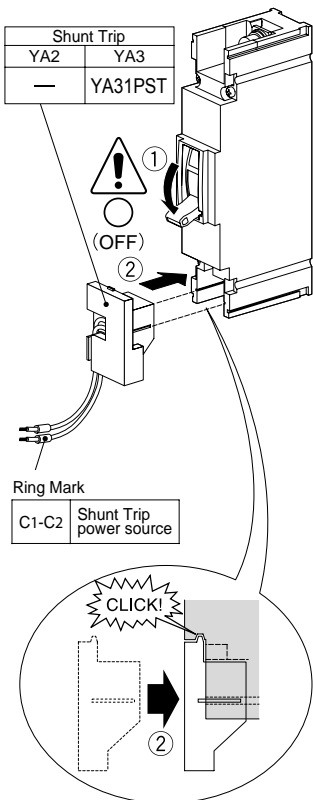

- \* After fitting, verify the function of the Accessory.
- \* When removing, remove the items in reverse order of mounting.

## 8 Procedure for mounting Terminal Cover

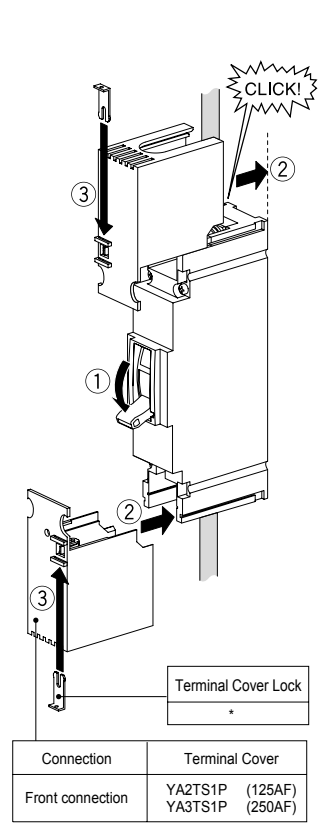

- \* When removing, remove the items in reverse order of mounting.
- \* 1 Unit: piece

## 9 Procedure for mounting Handle Holder/Lock

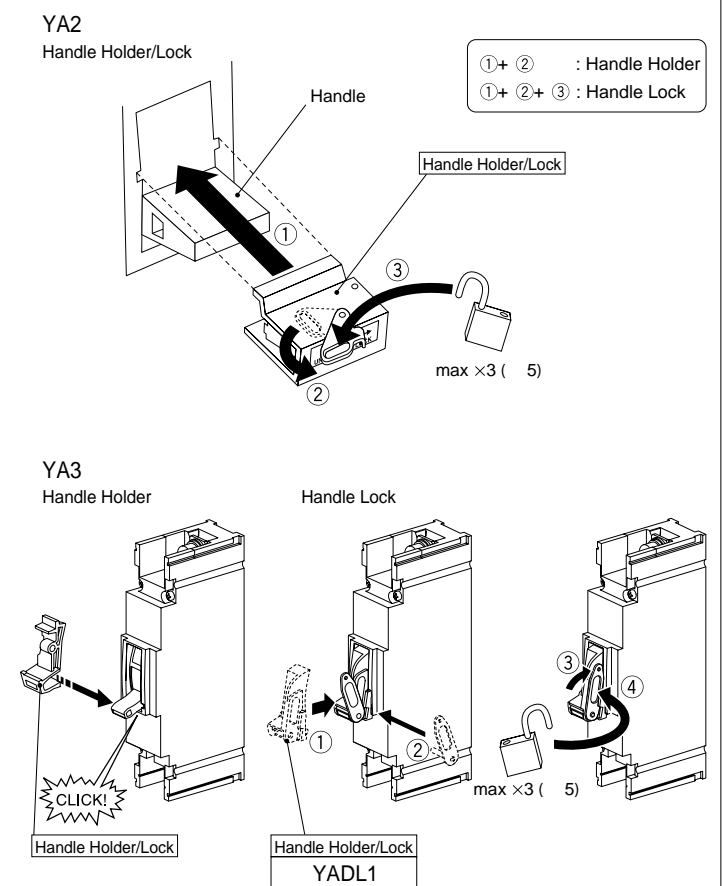

- \* When removing, remove the items in reverse order of mounting.