

YA7 GENERAL PURPOSE ENCLOSURE

FITTING INSTRUCTION

SHEET 1 OF 2

The following items are supplied with each unit :
 2 x Earth Bolt kit T12036
 8 x M12 x 50 Hex Hd screws, nuts & washers

1 : Remove the front & end plates

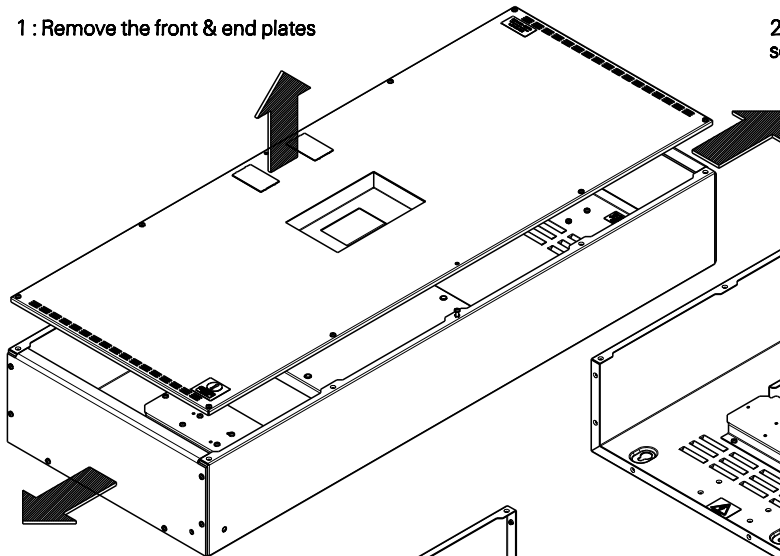

2 : Fit the YA7 MCCB using the M8 x 50 screws provided with the MCCB

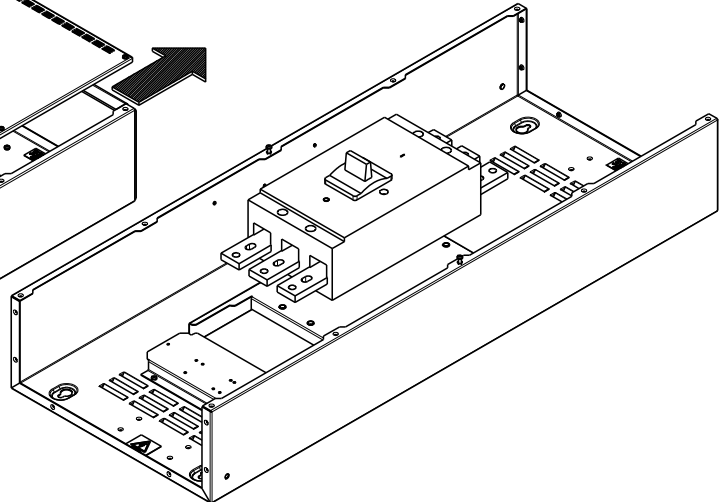

3 : If required fit the neutral link assembly Cat No Y7NL (ordered seperately) next to the MCCB.

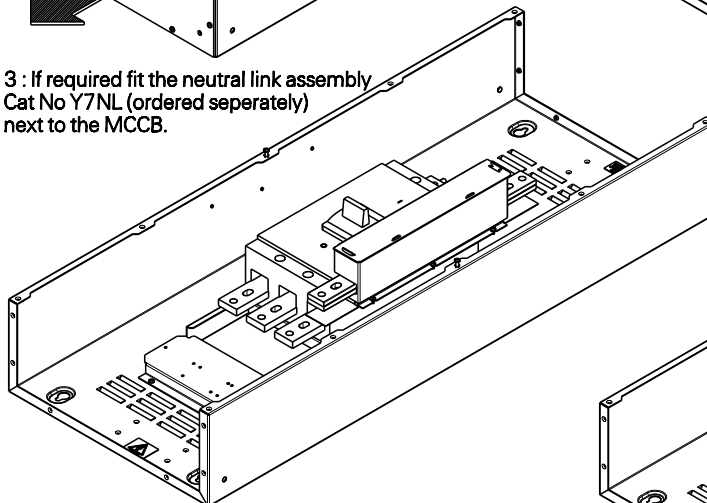

4 : If metering is required, remove the 5.50 dia knockouts in the side of the box & fit the meter mounting plate Cat No LLGPMP (ordered seperately) in position as shown using the M5 x 8 tapitite screws provided.

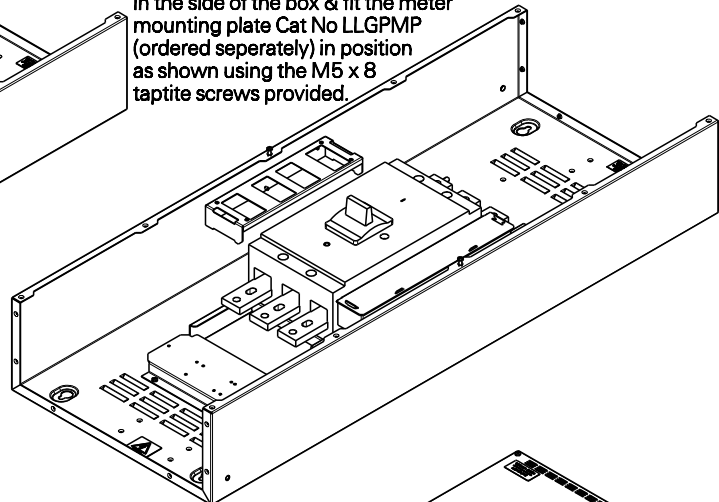

5 : Clip the meter(s) Cat No Ri3-01 and/or Cat No ELR1 (ordered seperately) onto the meter mounting plate as shown. Fit CT's as shown. the CT's and CT mounting plate can be fitted on the Load or Line side of the unit.

Note : DIN rail mounted fuse holders can fitted on the ends of the meter mounting plate.

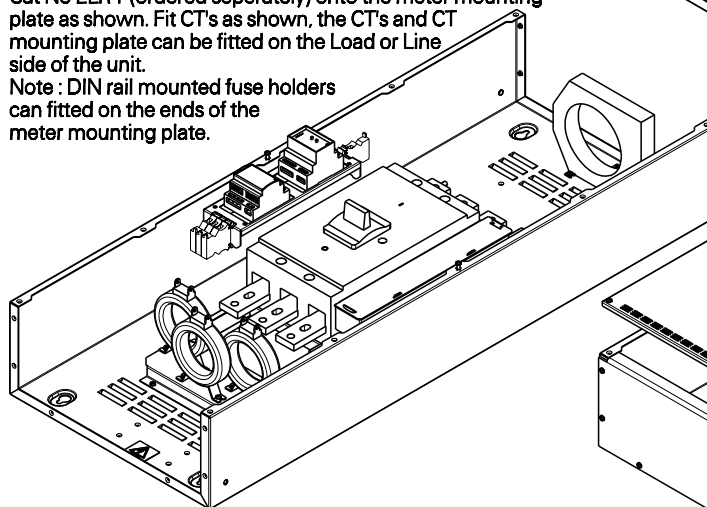

6 : Remove the appropriate front plate knockout to correspond with the meter position.

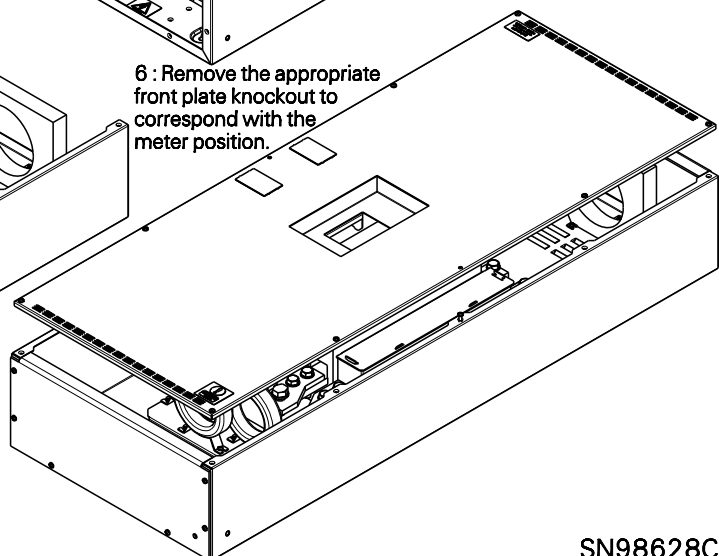

SN98628C

YA7 GENERAL PURPOSE ENCLOSURE

FITTING INSTRUCTION

SHEET 2 OF 2

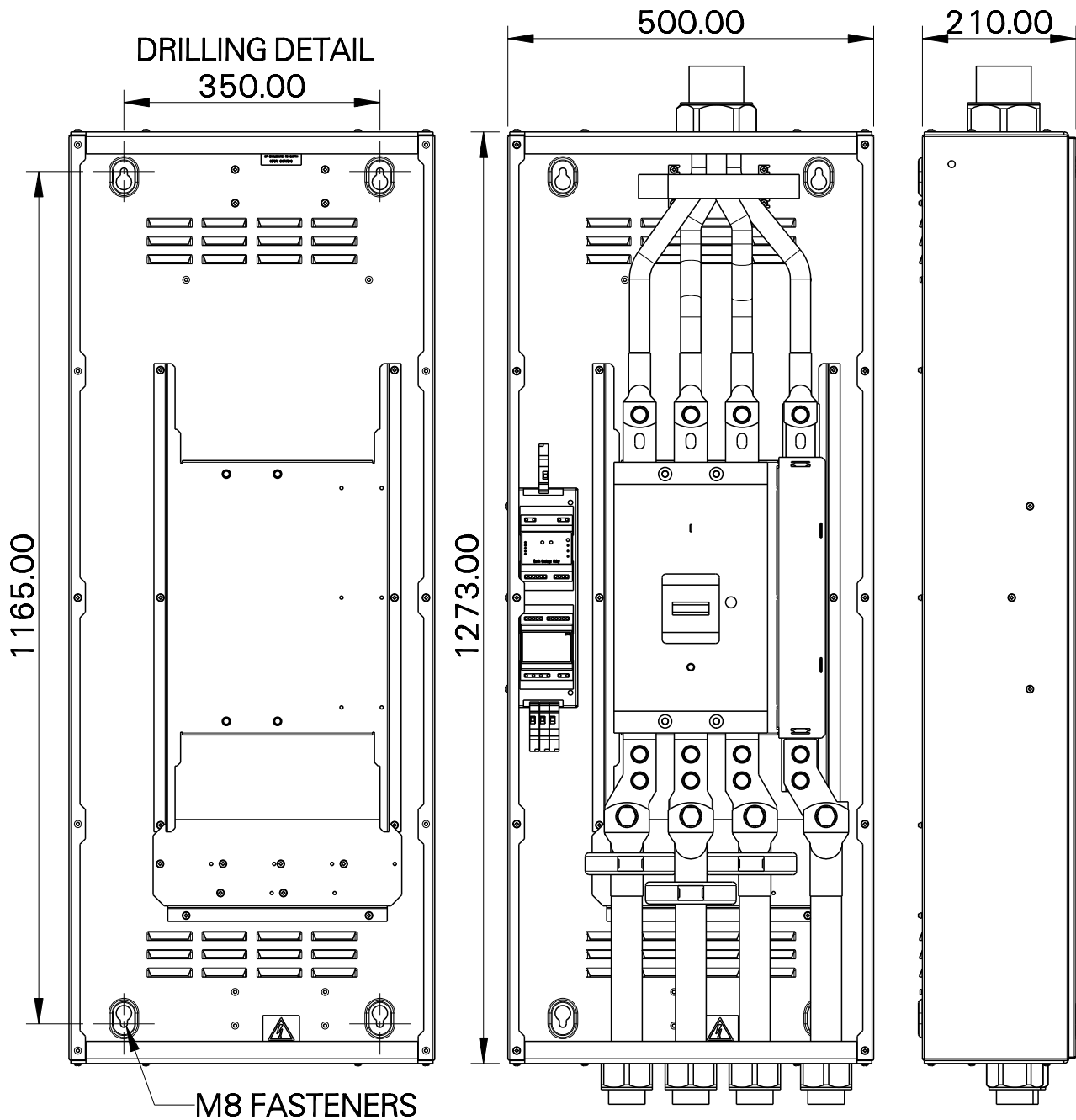

YA7 UNIT suitable for 2 x 4c 300mm cable
or sc 630mm cable with Terminal Extension kit Cat No LLGPYA7EXT.

7 : See MCCB instruction sheet for terminal screw torque values, for customer cable connection use the M12 x 50 fasteners provided. M12 torque value : 45Nm. On completion of cabling refit the end plates & front plate.

Installation and operation must be in accordance with published data, instructions and diagrams
and any relevant national and local regulations

SN98628C

DRG

M217841

REV

1